

## 产品规格书

## Specification

产品名称 (Product): 1/3" CMOS 彩色摄像模组(1/3" CMOS Color camera module)摄像头 (Camera Module): JDCD30S015 G00110版本号 (Version): R1.00镜头 (Lens): 2.5MM(940NM)

客户名称 (Cust.): \_\_\_\_\_

客户型号 (Cust.P/N): \_\_\_\_\_

日期 (Date): \_\_\_\_\_

客户 CUSTOMER			承制方 MANUFACTURER		
品质	工程	审批	审核	批准	销售
Quality	Engineer	Approved	Checked	Approved	Sales

# 目 录 Contents

目 录 Contents.....	2
版 本 Version.....	3
1. 概 况 Profile.....	4
2. 产品特性 Features.....	4
3. 应用范围 Application.....	4
4. 电气规格 Specifications.....	5
5. 可靠性测试 Reliability Testing.....	6
6. 结构图 Structure Diagram.....	7
7. 视场角 View Angle.....	8
8. 接口定义及时序图/Interface definition sequence diagram.....	9-10
9. 包装 Packing.....	11
10.外箱标签 Carton Box Mark.....	12
11.注意事项 Notes.....	12
12.命名规则 Naming Rule.....	13
13.配线 Accessory Cable.....	13

## 版本更改 Version

日期/Date	版本/Ver.	修改版本/Modification
2018-05-11	R1.00	第一版本 (The first version)

## 1. 概况 Profile:

JD CD30S015 G00110 CMOS 彩色摄像模组，采用 1/3" CMOS 影像传感器。适用于需要摄取视频信号的各种电子设备中，拥有宽动态，自动避免 50Hz 光源闪烁等功能。

JD CD30S015 G00110 CMOS color camera module, 1/3 "CMOS image sensor. It is applicable to all kinds of electronic devices that need to absorb video signal. It has wide dynamic and can avoid the flashing of 50Hz light source automatically.

## 2. 产品特性 Features

- 输出格式/Output format: yuv4:2:2
- 分辨率/Resolution: 1280\*720
- 宽动态/Wide dynamic range

## 3. 应用范围 Application

- 办公室电子设备 Office electronic device
- 仪器、仪表和测量用具 Equipment & Instrument and measuring tools
- 机器设备 Machine equipment
- 监视设备（车用监视器、便携视频采集、远程监视）  
Supervising equipment (Car Monitor & Portable video capture and remote monitoring)
- 家居用品（可视门铃、可视电话） Home supplies (Video door phone & video phone)

## 4. 电气规格 Specifications

NO	项目/Item	参数说明/Specification		备注/Remark
1	图像传感器/Image sensor	IMX224 1/3inch CMOS		
2	图像输出格式/Image Output Format	彩色/COLOR		YUV4:2:2
3	有效像素/Effective image pixel	1280*720		
4	同步方式/Synchronously	独立行、场同步信号 Independent line、field synchronization signal		
5	像素大小/Pixel size	3.75um*3.75um		
6	信噪比/ S/N radio	>48dB		
7	最低照度/Minimum illumination	0.01lux/F1.2		
8	曝光/Exposure	宽动态, 自动避免 50Hz 光源闪烁 Wide dynamic, Automatically avoid flashing 50Hz light sources		
9	夜视照明补偿	NC		
10	帧率/Frame	25FPS/30FPS		
11	启动时间/PowerUP Time	<500ms		
12	电源电压/Power Voltage	DC3.3V		
13	电流/Current consumption	<200mA		
14	工作温度范围	-20℃ ~ 70℃		
15	储存环境温度/ Storage Temp	-40℃ ~85℃		
16	湿度/Humidity	5~95% RH		
17	产品尺寸/Dimension	34.1 (L) × 34.22 (W) × 18.9 (H)		
18	镜头参数/Lens Parameter	焦距 Focus	2.5MM ± 5%	
		对角线视角 Diagonal view angle	130° ± 5%	
		水平视角 Horizontal view angle	110° ± 5%	
		垂直视角 Vertical view angle	60° ± 5%	
		对焦距离 Focus Distance	40CM	
		相对畸变 relative distortion	<-12%	
		光谱特性 Spectrum	940nm	

## 5. 可靠性测试 Reliability Testing

NO	试验项目 Testing Item	试验条件 Testing Conditions	判定标准 Judgment Standard
1	高温功能试验 High Temp. Test	高温 70℃; 8H 通电 high temp.70℃; 8H aging test	在 8H 测试中工作正常 Proper Functioning in 8H
2	低温功能试验 Low Temp. Test	低温-40℃; 8H 通电 low temp.-40℃; 8H aging test	在 8H 测试中工作正常 Proper Functioning in 8H
3	温湿度测试 Temp.& Humidity test	温度 70℃; 湿度 93%; 32H 通电 Temp.:70℃; Humidity 93%;32H aging test	在 32H 测试中工作正常 Proper Functioning in 32H
4	高温贮存试验 High Temp. storage test	温度 85℃; 8H Temp.:85℃;8H	恢复常温后产品产品正常 Proper Functioning after test
5	低温贮存试验 Low Temp. storage test	温度-40℃; 8H Temp.: -40℃;8H	恢复常温后产品产品正常 Proper Functioning after test
6	寿命试验 Aging Test	3.3V 通电; 连续开关机; 48H 3.3V DC; Continuous on/off; 48H	在 48H 测试冲击中工作正常 Proper Functioning after 48H
7	静电放电试验 ESD test	接触放电 Contact discharge: 6.0KV 空气放电 Air discharge: 8.0KV 水平/垂直接触放电: 8.0KV Horizontal / Vertical discharge: 8.0KV	产品功能和外观无问题 Function and appearance are all ok
8	振动试验 Vibration test	1. 振动标准: (1). 振动方向: Y 方向 (2). 振动幅度: 2mm (3). 振动频率: 10HZ to 50HZ (4). 振动表面: 紧靠一角的三个面 1. Vibration standard: (1).Direction: Y direction (2).Range:2mm (3).Frequency:10HZ to 50HZ (4).Surface:1 surface fixed when testing another 3 surface	振动后, 摄像机结构及功能应正常, 所有配套附件及吸塑不出现异常现象  The camera structure &function working good after vibration, all accessories& blister have no change.
9	跌落试验 Drop test	跌落高度/Distance height:30~150cm	跌落后, 摄像机结构及功能应正常, 所有配套附件及吸塑不出现异常现象  The camera structure and function is normal after dropped, all of accessories& blister are well.

## 6. 结构图 Structure Diagram

以下标注尺寸单位为: mm, 公差为±0.2mm(已标注公差除外)

Following size units are: mm, tolerance ±0.2mm(exclude marked)

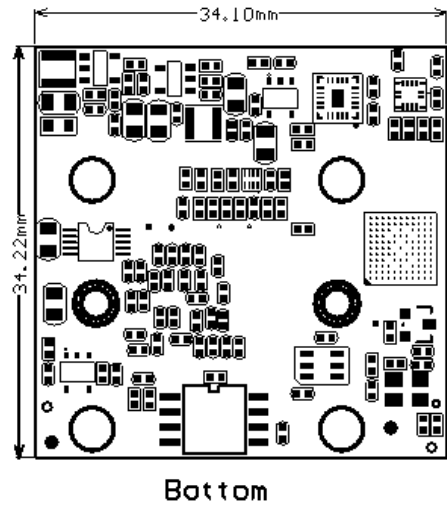
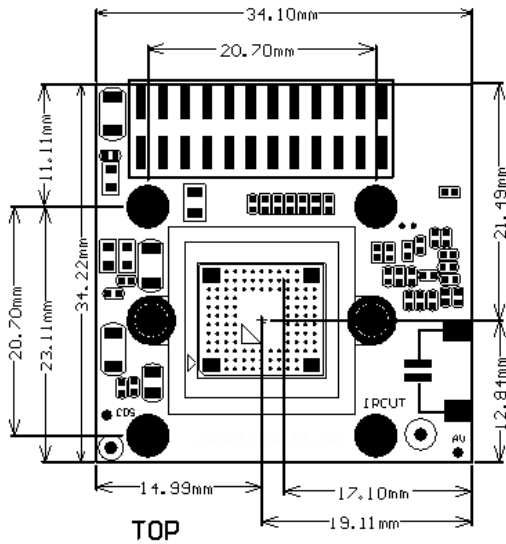

## 实物图/Physical map

正面图/Front view

侧面图 /Side view

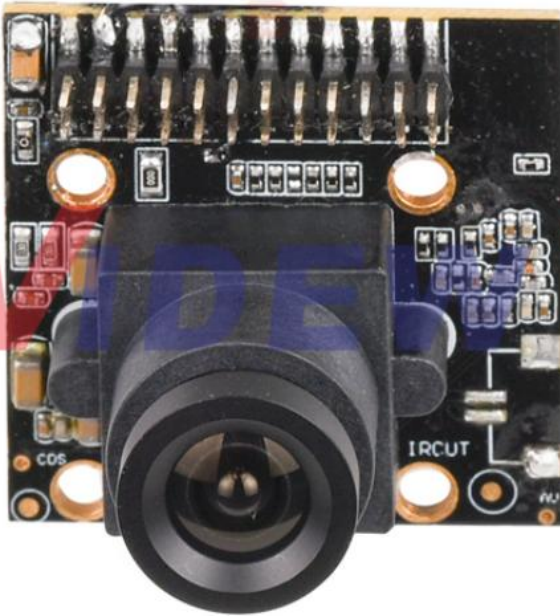

## 7. 视场角 View Angle

标注尺寸单位为: mm, 公差为±0.2mm

Size units are: mm, tolerance ±0.2mm

### 侧视图/Side view

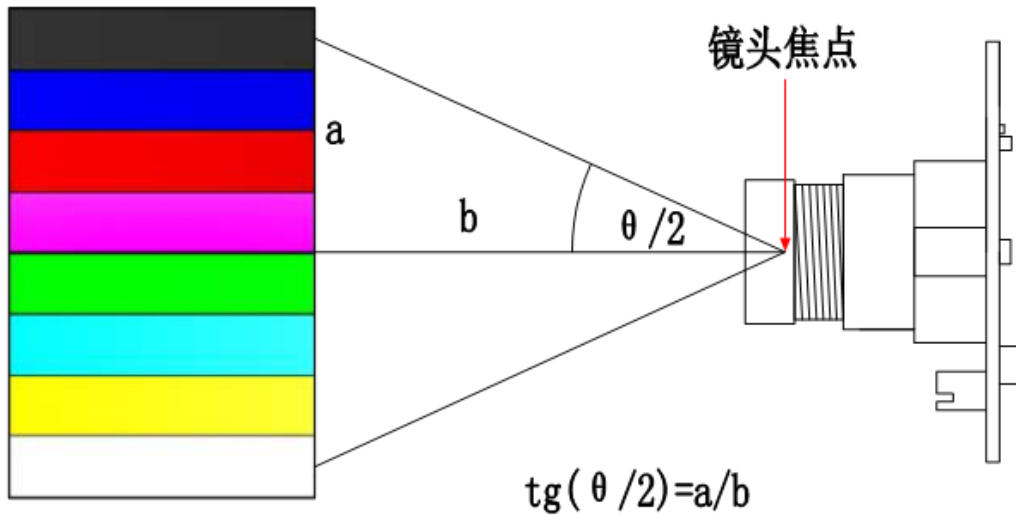
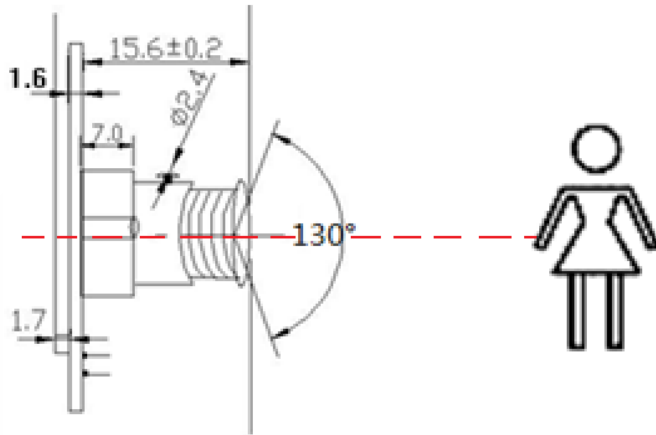

注: 测量全景时镜头到彩条板距离 b, 可以约算出视角

Note: The view angle could be calculated though measure b distance between lens to testing board.



## 8. 接口定义及时序图/Interface definition sequence diagram

### 8.1 接口定义/Interface Definitions

24PIN-2MM-针座					
J1 13151212CNG4M7.5O02					
GND	1	GND	DATA0	24	VID0
VID1	2	DATA1	DATA2	23	VID2
VID3	3	DATA3	DATA4	22	VID4
VID5	4	DATA5	DATA6	21	VID6
VID7	5	DATA7	GND	20	GND
GND	6	GND	NC	19	
PCLK	7	PCLK	GND	18	GND
VSYNC	8	VS	GND	17	GND
HSYVC	9	HS	+3.3V	16	3.3V
3.3V	10	+3.3V	RST	15	RST
SCL	11	SCL	PWDN	14	
SDA	12	SDA	LED	13	

NO.	Name	Type	Description
1	GND	P	数字地/Digital ground
2	D1	O	数字信号输出/Pixel data output
3	D3	O	数字信号输出/Pixel data output
4	D5	O	数字信号输出/Pixel data output
5	D7	O	数字信号输出/Pixel data output
6	GND	P	数字地/Digital ground
7	PCLK	O	PCLK 输出/Pixel clock output
8	VSYNC	O	场同步信号/VSYNC
9	HSYNC	O	行同步信号/HSYNC
10	POWER	P	+3.3V 输入/Power supply (3.3V)
11	SCL	I/O	I2C 通讯/I2C communication
12	SDA	I/O	I2C 通讯/I2C communication
13	NC		
14	NC		
15	RST	I	复位信号/RESET
16	POWER	P	+3.3V 输入/Power supply (3.3V)
17	GND	P	数字地/Digital ground
18	GND	P	数字地/Digital ground
19	NC		
20	GND	P	数字地/Digital ground
21	D6	O	数字信号输出/Pixel data output
22	D4	O	数字信号输出/Pixel data output
23	D2	O	数字信号输出/Pixel data output
24	D0	O	数字信号输出/Pixel data output

## 8.2. 输出时序/Output sequence

项目/Item	频率/Frequency	备注/Note
PCLK	62.50 MHz	
Vsyn	25.00 Hz	高有效/ Activehigh
Hsyn	22.32/11.26 KHz	高有效/ Activehigh
Video output sequence	Cb0Y0Cr1Y...	

### 8.2.1 时序图/Timing diagram

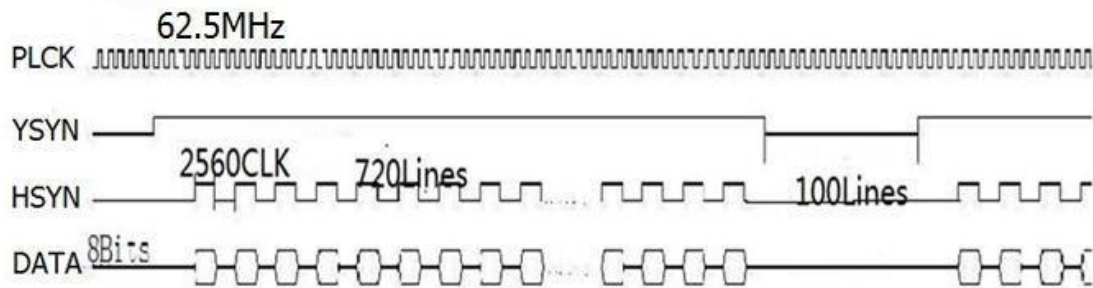

## 9. 包装 Packing



**步骤 1：** 将摄像模块放入静电袋中，用封口机封好

Step1: Put the camera module into the electrostatic bag and seal it with the sealing machine.

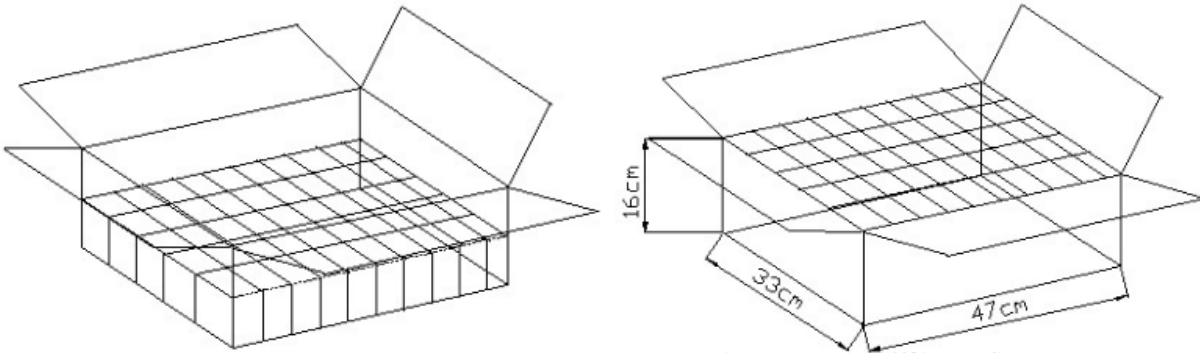

**步骤 2：** 将用静电袋装好的摄像头模块逐个放入纸箱的第一层中。

Step2: The electrostatic bag camera module is put into the first layer of the carton one by one.

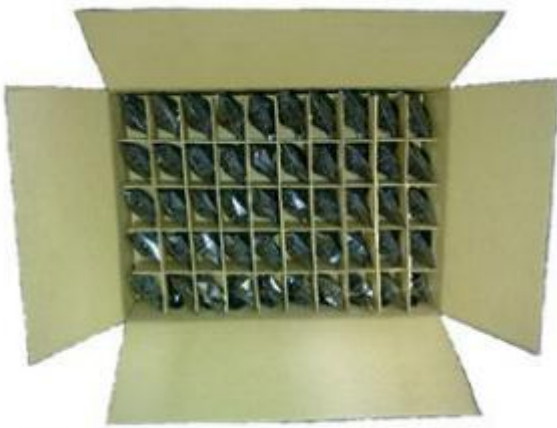

**步骤 4：** 检验员检验合格后放入合格证。

Step4 : After the inspector has passed the

**步骤 3：** 纸箱的第一层放满后，继续放纸箱的纸箱的第二层，直到放满为止。

Step3: When the first layer of the carton is full,continue second layers until it is full

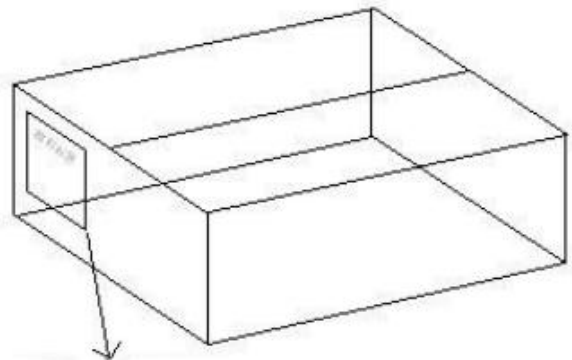

**步骤 5：** 贴好物品标签并用胶纸包好纸箱。

Step5 : Label the goods and wrap

## 10. 外箱标签 Carton Mark

外箱标签的内容如下 The carton box mark include below information:

厂家码 Vendor Number :

订单号 Order Number :

物料规格 Part Specifications :

原料编号 Part Number :

生产日期 Production Date :

交货数量 Delivery Qty :

保障期限 Delivery Date :

备注 Remark :

## 11. 注意事项 Notes

- 1、输入电压请勿超过规格书上规定值以免损坏模组。

The input voltage don't exceed the value stated on the specification , in order to avoid damage to the module.

- 2、接口连接线不能接反，接反容易烧坏板子，对产品的使用造成影响。

The connector can't be reversed , reverse burn the board and affect the use of the product.

- 3、此驱动板为电子产品,所以加工、组装、操作时需注意防静电措施，以免影响产品性能。

This is a electronic product, so processing, assembly , operation need to take anti -static measures to avoid affecting product performance.

- 4、镜头是玻璃制品小心拿放，以免破裂。

Lens is glass product, place carefully to avoid breakage.

- 5、镜头是玻璃制品注意防尘、防损，以免影响图像较果。

Lens is glass-made product, please take anti-dust, loss prevention measures to prevent the image quality.

## 12. 命名规则 Naming Rule

JD30S015 G00110 R1.00

硬件版本 Hardware Ver.:1.00

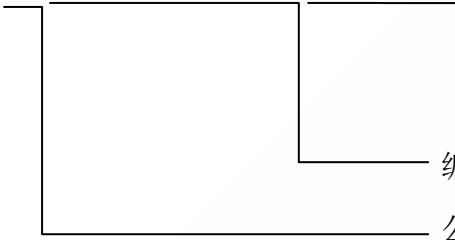

编号 Number: CD30S015 G00110

公司代号:深九鼎 (Company: XJD LIMITED)

## 13. 配线 Accessory Cable

无配线

No Accessory